

Transient Voltage Suppressors (TVS) Data Sheet

Features

- Glass passivated junction
- Low zener impedance
- Excellent clamping capability
- 8000W peak pulse power capability at 10/1000 μ s waveform, repetition rate (duty cycle):0.01%
- Fast response time
- Typical I_R less than 1 μ A above 11V.
- Plastic package has underwriters laboratory flammability 94V-0
- Meets MSL level 1, per J-STD-020.
- AEC-Q101 Qualified

Mechanical Data

- Case: JEDEC P600Moulded plastic
- Terminal:solderplated, solderable per MIL-STD-750, Method 2026
- Polarity: Color band denotes cathode except bi-directional models
- Mounting Position: Any

Applications

- I/O interface
- AC/DC power supply
- Automotive

Maximum Ratings and Characteristics

Ratings at 25 $^{\circ}$ C ambient temperature unless otherwise specified.

Rating	Symbol	Value	Units
Peak pulse power dissipation at 10/1000 μ s waveform (Note1, Fig.1)	P_{PPM}	Minimum 8000	Watts
Peak pulse current of at 10/1000 μ s waveform (Note 1, Fig.3)	I_{PPM}	See Table	Amps
Steady state power dissipation at $T_L=75^{\circ}$ C (Fig.4)	$P_{M(AV)}$	8	Watts
Peak forward surge current, 8.3ms single half sine-wave superimposed on rated load, (JEDEC Method) (Note2)	I_{FSM}	500	Amps
Operating junction and Storage Temperature Range.	T_J, T_{STG}	-55 to +150	$^{\circ}$ C
Typical thermal resistance junction to lead	$R_{\theta JL}$	8	$^{\circ}$ C/W
Typical thermal resistance junction to ambient	$R_{\theta JA}$	40	$^{\circ}$ C/W

Notes: 1. Non-repetitive current pulse, per Fig.3 and derated above $T_A=25^{\circ}$ C per Fig.2.

2. 8.3ms single half sine-wave, or equivalent square wave, duty cycle=4 pulses per minutes maximum.

Dimensions (P600)

Symbol	Millimeters		Inches	
	Min.	Max.	Min.	Max.
L	25.40	-	1.000	-
T	8.60	9.10	0.340	0.360
d	8.60	9.10	0.340	0.360
s	1.20	1.30	0.047	0.051

Electrical Characteristics (TA=25°C)

Part Number		Reverse Stand-Off Voltage	Breakdown Voltage @I _T	Test Current	Maximum Clamping Voltage @I _{PP}	Peak Pulse Current	Reverse Leakage @V _{RWM}
Unidirectional	Bidirectional	V _{RWM} (V)	V _{BR} (V)	I _T (mA)	V _C (V)	I _{PP} (A)	I _R (μA)
8KP28A-AR	8KP28CA-AR	28	31.1~34.4	1	45.4	176	1
8KP30A-AR	8KP30CA-AR	30	33.3~36.8	1	48.4	165	1
8KP33A-AR	8KP33CA-AR	33	36.7~40.6	1	53.3	150	1
8KP36A-AR	8KP36CA-AR	36	40.0~44.2	1	58.1	138	1
8KP40A-AR	8KP40CA-AR	40	44.4~49.1	1	64.5	124	1
8KP43A-AR	8KP43CA-AR	43	47.8~52.8	1	69.4	115	1
8KP45A-AR	8KP45CA-AR	45	50.0~55.3	1	72.7	110	1
8KP48A-AR	8KP48CA-AR	48	53.3~58.9	1	77.4	103	1
8KP51A-AR	8KP51CA-AR	51	56.7~62.7	1	82.4	97	1
8KP54A-AR	8KP54CA-AR	54	60.0~66.3	1	87.1	92	1
8KP58A-AR	8KP58CA-AR	58	64.4~71.2	1	93.6	85	1
8KP60A-AR	8KP60CA-AR	60	66.7~73.7	1	96.8	83	1
8KP64A-AR	8KP64CA-AR	64	71.1~78.6	1	103	78	1
8KP70A-AR	8KP70CA-AR	70	77.8~86.0	1	113	71	1
8KP75A-AR	8KP75CA-AR	75	83.3~92.1	1	121	66	1
8KP78A-AR	8KP78CA-AR	78	86.7~95.8	1	126	63	1
8KP85A-AR	8KP85CA-AR	85	94.4~104	1	137	58	1
8KP90A-AR	8KP90CA-AR	90	100~111	1	146	55	1
8KP100A-AR	8KP100CA-AR	100	111~123	1	162	49	1
8KP110A-AR	8KP110CA-AR	110	122~135	1	177	45	1
8KP120A-AR	8KP120CA-AR	120	133~147	1	193	41	1
8KP130A-AR	8KP130CA-AR	130	144~159	1	209	38	1
8KP150A-AR	8KP150CA-AR	150	167~185	1	243	33	1
8KP160A-AR	8KP160CA-AR	160	178~197	1	259	31	1
8KP170A-AR	8KP170CA-AR	170	189~209	1	275	29	1

Notes: For bidirectional type having VRWM of 10V and less, the IR limit is double.

Recommended Soldering Conditions

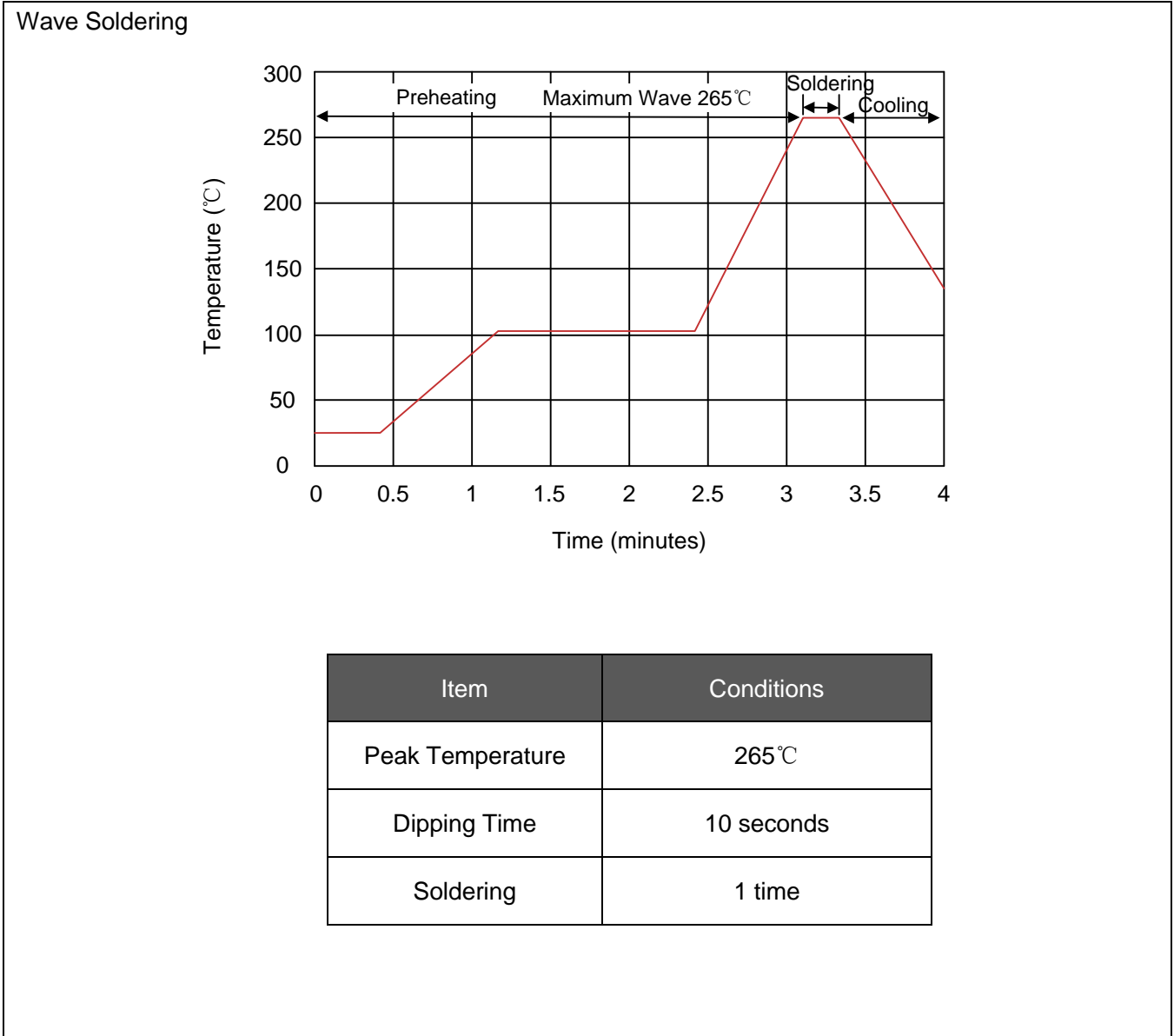

Partnumber code

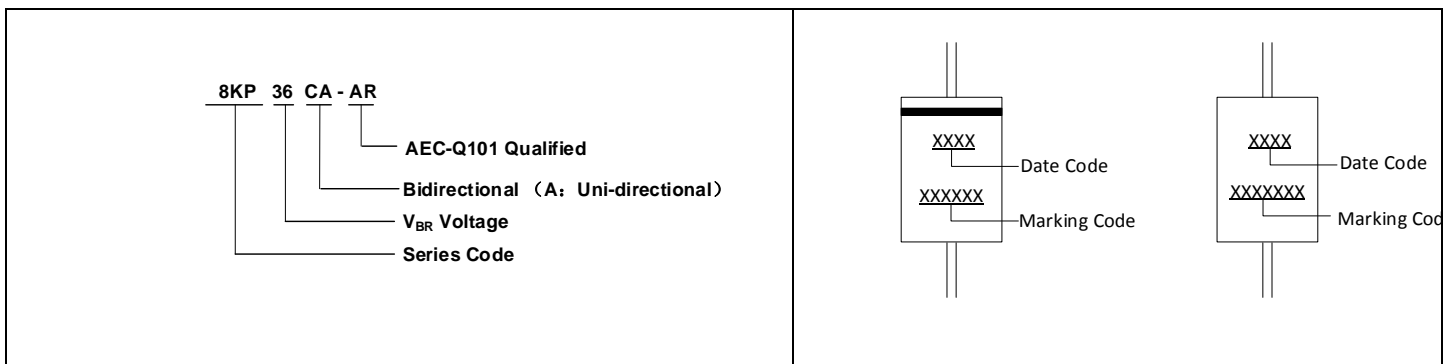

Ratings and Characteristic Curves ($T_A=25^\circ\text{C}$ unless otherwise noted)

Figure 1. Peak Pulse Power Rating Curve

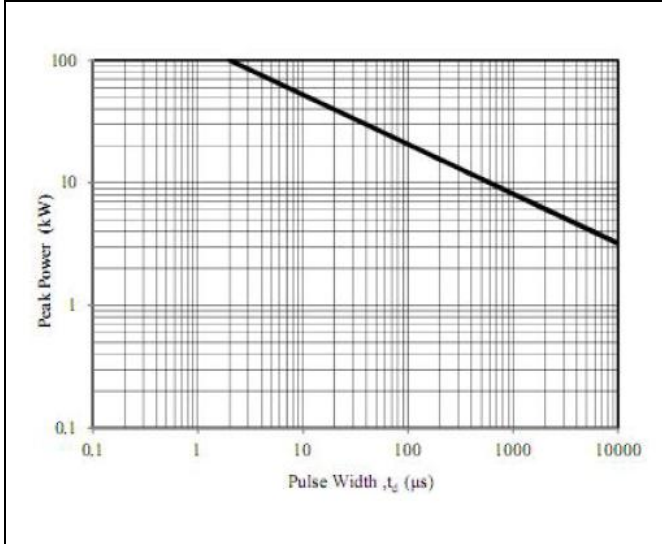

Figure 2. Pulse Derating Curve

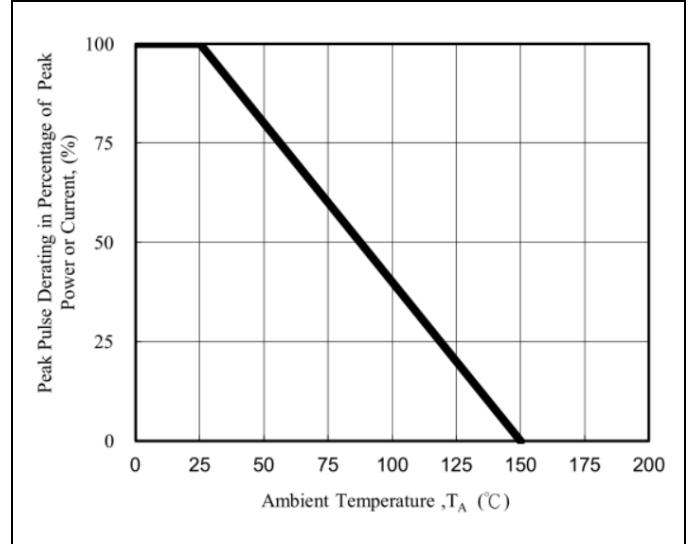

Figure 3. Pulse Waveform

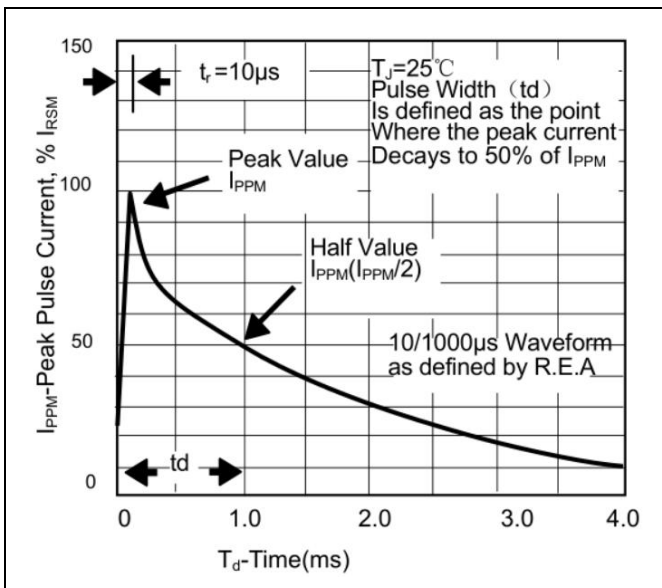
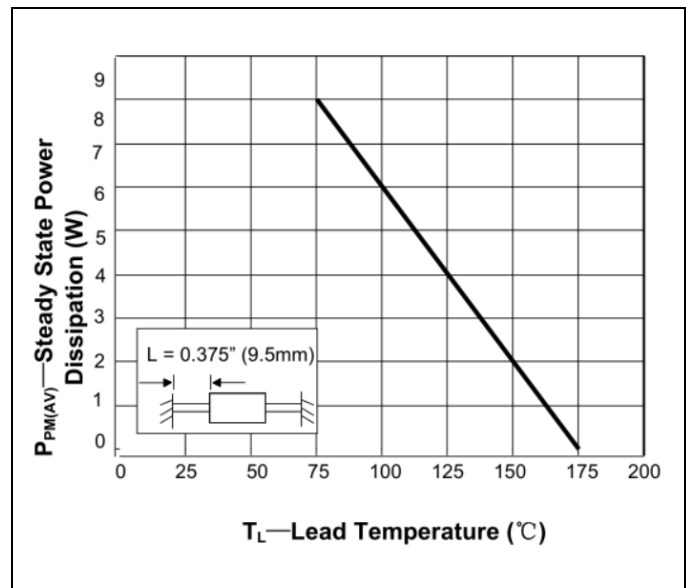
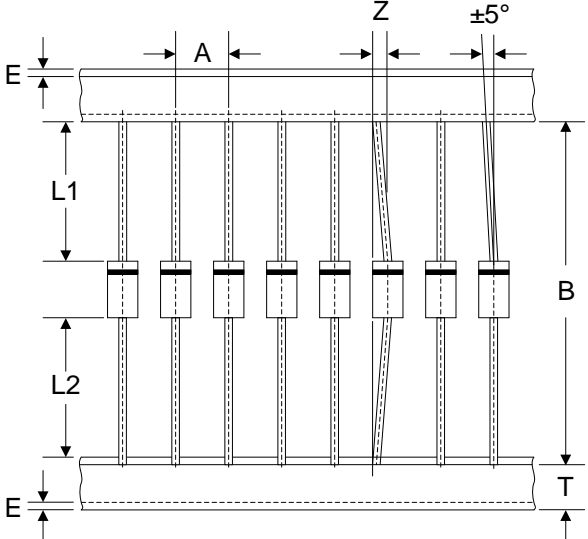
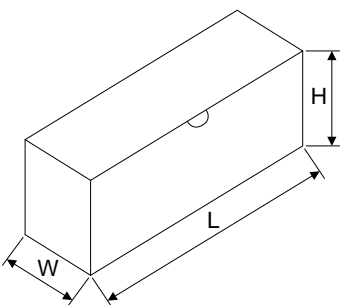

Figure 4. Steady State Power Dissipation Derating Curve



Packaging

Tape	Symbol	Dimension (mm)	
	A	10.0±0.5	
	B	53.0±1.0	
	Z	1.2Max.	
	T	6.0±0.4	
	E	0.8Max.	
	L1-L2	1.0Max.	
		L	260.0±5.0
		W	75.0±5.0
H		145.0±5.0	
Quantity: 300PCS			